

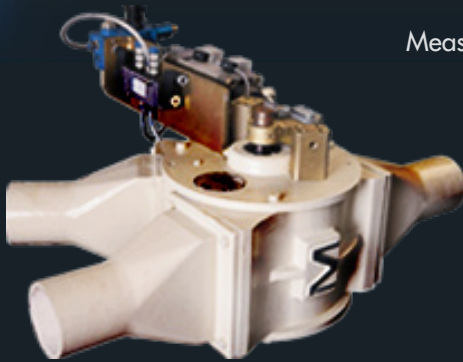

DIVERGENT VALVES

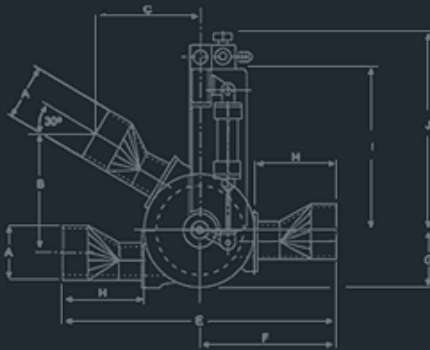

Measurements:



- Open channel (to avoid pressure drops)
- 30° inclination at entrance and exit
- For pressure systems or vacuum systems
- Manual operation with a pneumatic activator
- Sealed bearings, no lubrication required
- Abrasive, granular, fine or pellet materials
- Rotor turn at a 50° radius
- Made of gray iron, nodular iron, steel or aluminum
- Tubing, schedule 40 or ASA flanged nozzles.
- Manufactured in 2", 3", 4", 5" and 6"
- P.L.C. control (optional)

Note:

- Manually operated valve; or
- Automatically operated valve

Note:

- Pin shaft on both ends (W)
- Use ER-19 type bearing (Seal Master) 2 parts
- Gaskets No. 11841-NU-8 (MCA. C/R) 2 parts

CHART FOR PIPE

MODEL N°	PIPE CALIBER	TYPE OF PIPE	A	B	C	D	E	F	G	H	I	J	W	X
VDT-2	2"	Tubing	2"Ø	11-3/32"	12-3/16"	1-3/16"	1-3/16"	14-3/4"	5"	9-3/4"	18"	22"	2-1/16"	8"
VDT-3	3"	Tubing	3"Ø	11"	11-15/16"	1-3/16"	1-3/16"	14-3/4"	5"	9-3/4"	18"	22"	2-1/16"	8"
VDT-4	4"	Tubing	4"Ø	10-15/16"	11-11/16"	1-3/16"	1-3/16"	14-3/4"	5"	9-3/4"	18"	22"	2-1/16"	8"
VDT-5	5"	Tubing	5"Ø	13-1/8"	12-1/4"	1-3/16"	1-3/16"	15-7/8"	6-3/8"	9-3/4"	18"	22"	2-1/16"	8-7/8"
VDT-6	6"	Tubing	6"Ø	13"	12"	1-3/16"	1-3/16"	15-7/8"	6-3/8"	9-3/4"	18"	22"	2-1/16"	8-7/8"

CHART FOR SCHEDULE 40 PIPE

MODEL N°	PIPE CALIBER	TYPE OF PIPE	A	B	C	D	E	F	G	H	I	J	W	X
VDP-2	2"	CED .40	2-3/8"	11-1/16"	12-1/16"	1-3/16"	29-1/2"	14-3/4"	5"	9-3/4"	18"	22"	2-1/16"	8"
VDP-3	3"	CED .40	3-1/2"	11"	11-13/16"	1-3/16"	29-1/2"	14-3/4"	5"	9-3/4"	18"	22"	2-1/16"	8"
VDP-4	4"	CED .40	4-1/2"	10-13/16"	11-9/16"	1-3/16"	29-1/2"	14-3/4"	5"	9-3/4"	18"	22"	2-1/16"	8"
VDP-5	5"	CED .40	5-9/16"	13-3/16"	12-1/8"	1-3/16"	31-3/4"	15-7/8"	6-3/8"	9-3/4"	18"	22"	2-1/16"	8-7/8"
VDP-6	6"	CED .40	6-5/8"	13-1/8"	11-7/8"	1-3/16"	31-3/4"	15-7/8"	6-3/8"	9-3/4"	18"	22"	2-1/16"	8-7/8"

CHART FOR SCHEDULE 40 PIPE WITH FLANGE

MODEL N°	PIPE CALIBER	TYPE OF PIPE	A	B	C	D	E	F	G	H	I	J	W	X
VDP-2-B	2"	CED .40	2-3/8"	10-1/2"	11-1/8"	1-3/16"	27-1/4"	13-5/8"	5"	8-5/8"	18"	22"	2-1/16"	8"
VDP-3-B	3"	CED .40	3-1/2"	10-7/16"	10-7/8"	1-3/16"	27-1/4"	13-5/8"	5"	8-5/8"	18"	22"	2-1/16"	8"
VDP-4-B	4"	CED .40	4-1/2"	10-1/4"	10-9/16"	1-3/16"	27-1/4"	13-5/8"	5"	8-5/8"	18"	22"	2-1/16"	8"
VDP-5-B	5"	CED .40	5-9/16"	12-9/16"	11-1/8"	1-3/16"	29-1/2"	14-3/4"	6-3/8"	8-5/8"	18"	22"	2-1/16"	8-7/8"
VDP-6-B	6"	CED .40	6-5/8"	12-1/2"	10-7/8"	1-3/16"	29-1/2"	14-3/4"	6-3/8"	8-5/8"	18"	22"	2-1/16"	8-7/8"